

PROCEN TEC



Installation Manual (English) **Active DP Terminator T1** Active PROFIBUS DP segment termination

All baudrates
Redundant power supply
DB9 connector for maintenance activities
IP 20 with DIN-rail mounting

PROCEN TEC
Turfschipper 41
2292 JC WATERINGEN
The Netherlands

Tel.: +31-(0)174-671800
Fax: +31-(0)174-671801
Email: info@procentec.com
Web: www.procentec.com

Introduction

The T1 Terminator provides active and reliable termination for PROFIBUS networks which are based on RS 485. By using this component it is possible to turn off, remove or replace devices without disturbing the bus communication. This applies in particular to the devices at the end of the segment.

The T1 has a couple of special features which makes it a very useful infrastructure component; it has a redundant power supply and diagnostic LEDs to indicate the status of each power source. It is also equipped with an additional DB9 connector for ProfiTrace or other maintenance/engineering tool. The DB9 connector can also be used as the primary bus connection if circumstances so dictate.

The T1 Terminator can be installed on a standard DIN-rail.

Installation instructions

Location

The T1 Terminator can be installed everywhere in a non-hazardous area that complies with IP 20 (DIN 40 050) and the specified temperature range of -20 to +60° Celsius.

Position

The T1 Terminator can be installed in every position, but it is recommended to install it with the green PROFIBUS connector pointing down. In this position it is easier to read the status display and to perform measurements on the DB9 connector.

Mounting and dismounting

The T1 Terminator has to be mounted on a 35 mm DIN-rail with a minimum width of 60 mm. Fig. 1 and Fig. 2 illustrate how to mount and dismount the T1 on and from the DIN-rail.

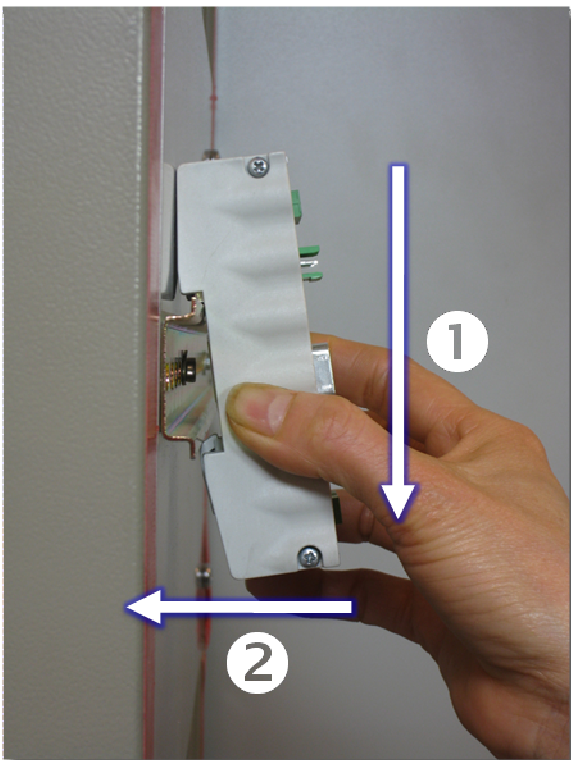

Fig. 1 Mounting; pull-down and push

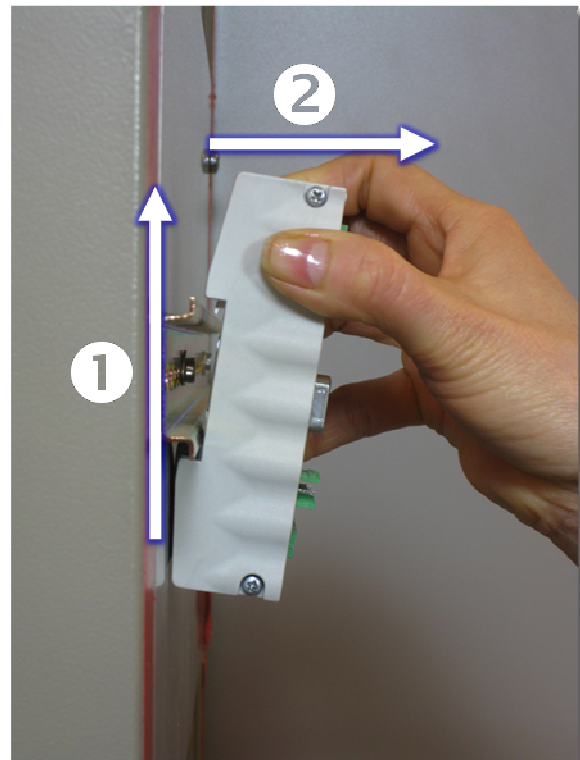

Fig. 2 Dismounting; Push-up and pull

Power supply

Parameters

The power supply has to comply with the following specifications:
 Voltage: **19 to 28 Vdc**
 Current: **Min. 65 mA**

Redundancy

Both power connectors are linked 1-on-1 to the internal power supply of the T1. If 1 power supply would fail, the other takes over without delay time. When redundancy is not required, it is sufficient to use 1 power connector. When the T1 is flipped 180°, the connectors can be used without alteration. Fig. 3 illustrates the location of the power supply connectors.

Wiring

The leads of both power connectors have to be wired as follows:
 “-“ = 0 V
 “+“ = Positive Voltage
 SH = Earth

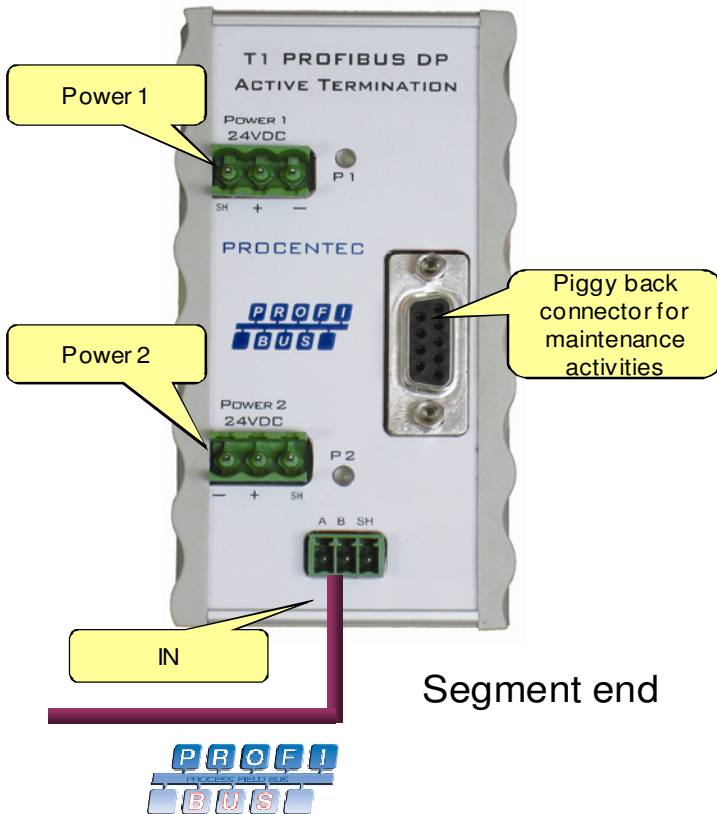

PROFIBUS

Screw connector

The T1 Terminator has 1 PROFIBUS connector, this is where the DP segment ends. It is common practise to connect the PROFIBUS cable to the green screw connector. This keeps the DB9 connector available for maintenance activities.

Pin layout

Pin “A”: Green wire
 Pin “B”: Red wire
 Pin “SH”: Cable shielding

Piggy back connector

The piggy back DB9 connector is connected 1-on-1 with the PROFIBUS screw connector.

Ground Clip

It is recommended to use the supplied GC-01 ground clip to attach the cable shield to the screw connector, as shown in figure 4, for easier shield connection and better strain relief.

The Ground Clip GC-01 can be ordered separately per 25pcs with order code **101-00201B**

Fig. 3 Structure of the T1

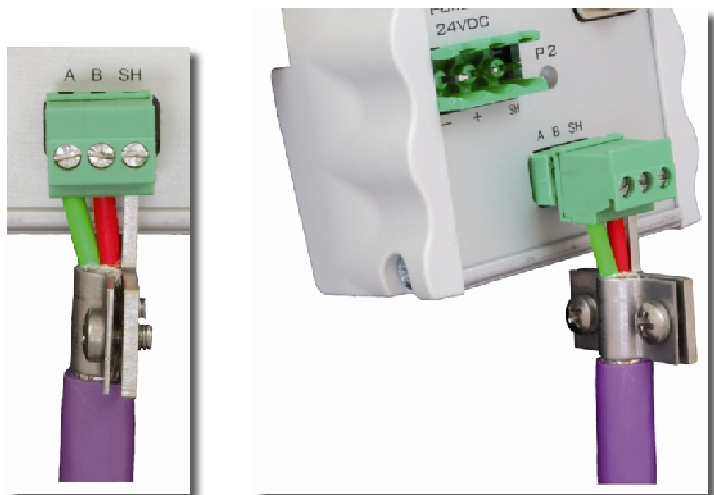

Fig. 4 Using the Ground Clip

Diagnostic LEDs

	OFF	Blinking	ON
P1	☹ Power is OFF or an internal failure. Check if P2 is on.	⚠ Power supply not stable or an internal failure. Check if P2 is on.	😊 Power supply OK.
P2	☹ Power is OFF or an internal failure. Check if P1 is on.	⚠ Power supply not stable or an internal failure. Check if P1 is on.	😊 Power supply OK.

Technical Data Active PROFIBUS DP Termination T1	
Dimensions and weight	
Dimensions L x W x H (mm)	106 x 55 x 33 mm (without plugs) 106 x 55 x 55 mm (with plugs)
Weight	Approximately 125 g
Ambient conditions	
Operating temperature	-20 to +60° Celsius
Isolation class	IP 20 (DIN 40 050)
Protocol specifications	
Supported Protocols	DP-V0, DP- V1, DP-V2, FDL, MPI, FMS, PROFIsafe, PROFIdrive and any other FDL based protocol.
Transmission speed	9,6 kbps to 12 Mbps (including 45,45 kbps)
PROFIBUS cable specifications	
Cable lengths	1200 m at 9,6 kbps to 93,75 kbps 1000 m at 187,5 kbps 400 m at 500 kbps 200 m at 1,5 Mbps 100 m at 3 Mbps to 12 Mbps
Wire diameter	< 2,5 mm ²
Wire type	Stranded or Solid core
Termination	Powered according to IEC 61158 (390/220/390 Ohms)
Power supply specifications	
Nominal supply voltage	19 to 28 Vdc
Current consumption	65 mA at 24 Vdc
Power dissipation	Max. 2 W
Redundancy	Yes (Power 1 <u>OR</u> Power 2)
Power LED	Power 1 <u>OR</u> Power 2
Reverse polarity protection	Yes
Wire diameter	< 2,5 mm ²